

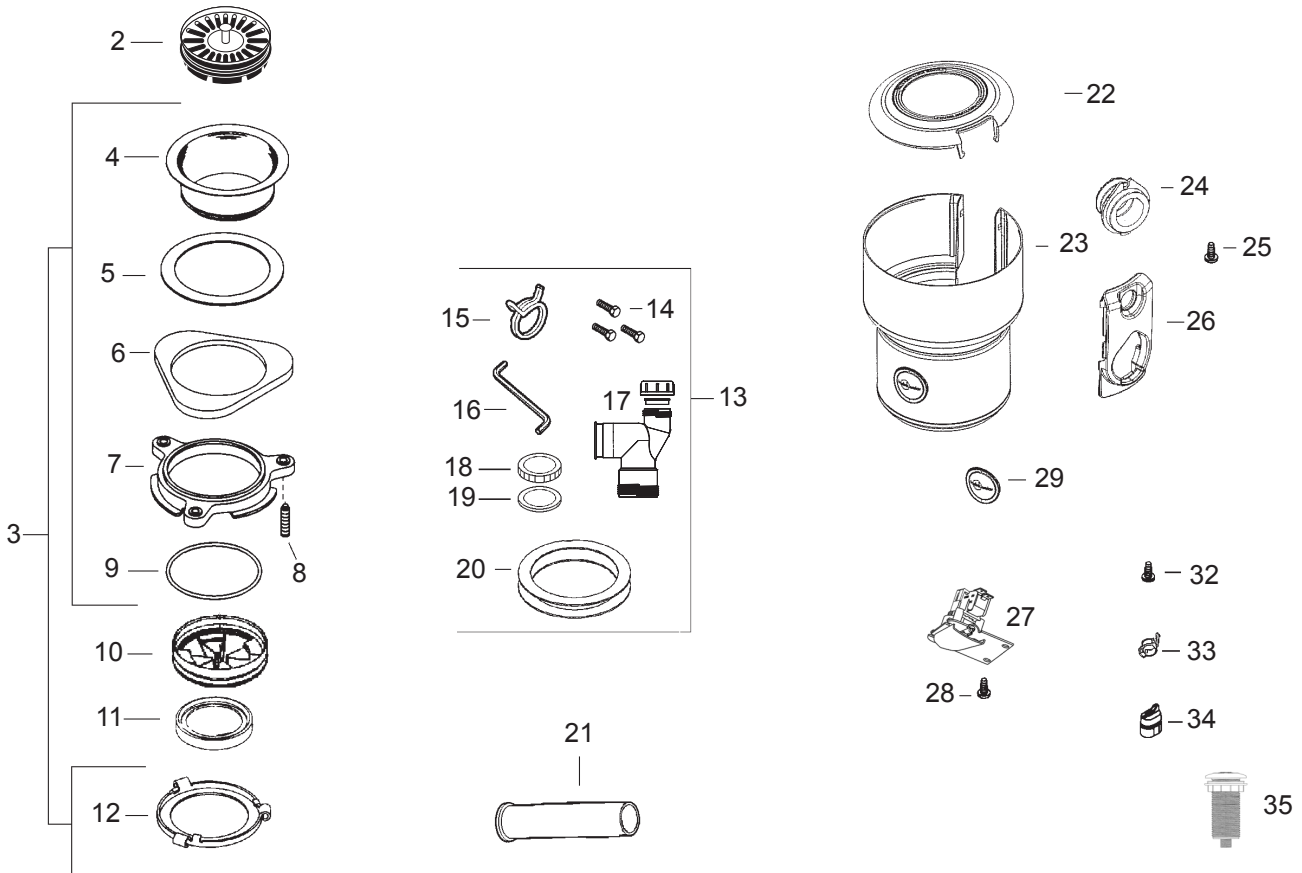

International Evolution Model 200™

200-3 Aust/NZ .75 HP 230-240V 50 HZ

Warranty:	6 Year Warranty
Production Date:	06/2009
Engineer Number:	75275/A, B, C, J



ORDER BY PART NUMBER, NOT CODE NUMBER

CODE NO.	PART NO.	NO. REQ.	DESCRIPTION	CODE NO.	PART NO.	NO. REQ.	DESCRIPTION
1	IP74552MZZ	1	Installation/Accessory Box (Includes Codes 2-21 & 35)	21	IP75220	1	12" Discharge Tube
2	IP75265	1	Stopper Assembly	22	IP73671	1	Trim Shell Cap
3	IP03173ED	1	Mounting Assembly (Includes Codes 4-9 & 12)	23	IP75280ZZ	1	Trim Shell (Includes Code 29)
4	IP10025P	1	Sink Flange	24	IP75499	1	Flex Coupler
5	IP01160	1	Fiber Gasket	25	IP74129	1	Screw
6	IP05150E	1	Backup Flange	26	IP73701	1	Boot
7	IP05141	1	Mounting Flange	27	IP72647A	1	Terminal Cover Assembly
8	IP74999	3	Backup Screws	28	IP75567	1	Screw
9	IP05166	1	Snap Ring	29	IP73786	1	Trim Shell Badge
10	IP74681A	1	Sink Baffle	30	IP75602	1	Cord Assy, 200-3 (Not Shown)
11	IP74054	1	Mounting Gasket	31	IP75266	1	ICU Manual, 200-3 (Not Shown)
12	IP05298	1	Body Flange	32	IP02466C	1	Screw, Ground
13	IP75268	1	Installation Kit (Includes Codes 14-20)	33	IP73404	1	Guard, Overload
14	N/A	1	Kit (3 short screws)	34	IP70667	1	Bushing
15	IP74701	1	Spring Clamp	35	IP75430	1	Air Switch Transmitter Assy
16	IP04577	1	Wrench				
17	N/A	1	Tailpipe				
18	N/A	1	Nut				
19	N/A	1	Seal				
20	IP08763	2	Gasket, Sink Flange				